

## Construction Specifications

- 1 Solid wood door and draw front frames either doweled and glued or mortise and tenon, depending on door.
- 2 Compact Blumotion soft-close mechanism integrated in concealed six-way adjustable hinges.\*
- 3 5/8" solid birch dovetail drawer with a 3/8" plywood bottom with Tandem plus Blumotion full extension concealed drawer runners.
- 4 3" interior drawer height.
- 5 3/4" x 1 1/2" solid wood face frame.
- 6 1/2" select birch veneered plywood back with a natural finished interior.
- 7 1/2" select birch veneered plywood side panels dovetailed into face frame.
- 8 18mm (3/4") select birch veneered plywood adjustable shelving with matching wood veneer edge banding.
- 9 3/4" x 4 1/2" solid wood toe kick finished to match exterior finish and attached to cabinet.
- 10 Wood corner blocks added for the support and mounting of a countertop.
- 11 1 1/2" x 1/2" plywood panel beams dovetailed into the side panels for strength and stability.
- 12 Base cabinet has 18" deep shelves.

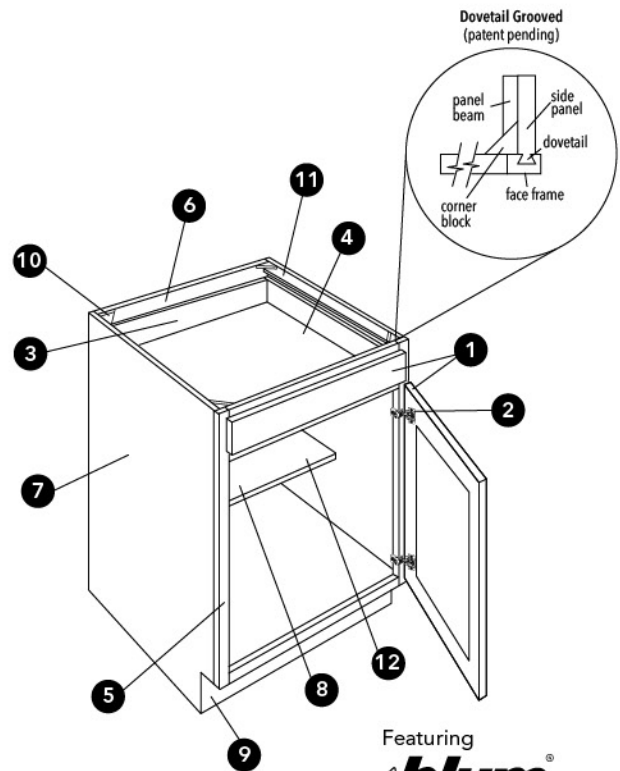
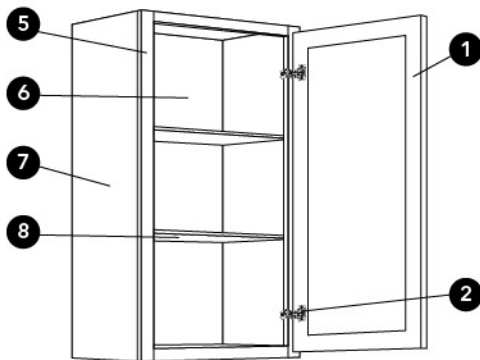

\* Elite doors feature Salice hinges.

Featuring  
**blum**<sup>®</sup>

## Construction Specifications

### Doors and Drawer Fronts:

Doors and drawer fronts on the Classic line are made of solid birch with a stain and glazed finish. The painted lines have an MDF center panel to reduce the possibility of shrinkage and is the preferred material for painted finishes.

### Wellington Door Series:

The 5 piece Wellington full overlay door has a solid 5/8" thick raised center panel captured in a 3/4" x 2 1/2" mortise and tenon frame. It has an applied moulding and is complemented with a 5 piece recessed panel drawer front.

### Elite Door Series:

The 5 piece Elite full overlay door has a solid 5/8" thick raised center panel captured in a 7/8" x 3" mitered frame assembled with dowels and finger jointed. This series is also complemented with a 5 piece recessed panel drawer front.

### Hinges:

Compact Blumotion soft-close mechanism integrated in concealed six-way adjustable hinges. Elite doors feature Salice hinges. Please note: Lazy Susan, Easy Reach and Pie Cut cabinets do not feature the soft-close mechanism.

### Drawers:

The Classic line includes a 5/8" thick solid birch dovetail drawer box with a 3/8" plywood bottom, attached to Tandem plus Blumotion full extension concealed drawer runners.

### Shelving:

18mm (3/4") thick select birch veneered plywood with matching wood veneer edge banding is used on all wall and base cabinetry where applicable. The adjustable shelves are supported by a nickel plated shelf clip. All base cabinetry includes an 18" deep adjustable shelf.

### Backs, Tops and Bottoms:

1/2" thick birch veneered plywood with natural finished interiors, dovetailed side panels engineered to create a solid integrated cabinet box. Backs are glued, stapled and screwed into place for additional support.

### Face Frame:

3/4" x 1 1/2" solid wood stiles and rails jointed with glue and dowels. Back of face frames are dovetail grooved to accept side panels. The face frame is engineered so that the bottom of all base and wall cabinets are flushed with the top inside edge of the face frame creating a custom look.

### Toe Kick:

3/4" x 4 1/2" solid birch toe kick is added to each assembled cabinet and finished to match along with the edges. Additional 8-foot lengths of 1/4" plywood toe kicks are available for those who do not wish to see the joints between cabinets.

### Corner Blocks and Panel Beams:

All four corners of the base cabinets are secured with a wooden block screwed into each end panel at a 45° angle for the support and mounting of a countertop. In addition a panel beam is glued and fastened into a dovetail groove at the top of each base cabinet to ensure a straight fully integrated side.

Copyright © 2018 by Fabuwood Cabinetry Corp.

All rights reserved.

No part of this publication may be reproduced, distributed, or transmitted in any form or by any means, including photocopying, scanning, or other electronic or mechanical methods, including online sharing, without the prior written permission of Fabuwood Cabinetry Corp.



## What exactly defines a Q12 cabinet?

To fully achieve Q12 eligibility, a cabinet must encompass twelve unique standards of quality. Read below to learn more about the twelve fundamental pillars that establish the Q12 qualification:

### Q1: QUALITY SOURCED LUMBER

This Q12 standard requires the use of carefully selected top-grade lumber, guaranteeing the finest and most dependable kitchen cabinets. To meet this requirement, Fabuwood has implemented a rigorous inspection process to assure that only first-class products, free of irregularities leave the plant.

### Q2: PRO TOUCH TECHNIQUES

To fully permeate a Q12 assessment, expert finishing methods are required to heavily influence first impressions and assure a lasting finish that is easy to maintain. Fabuwood's own pro touch technique uses renowned brands to create a durable, simple to clean cabinet that will hold its beauty for years.

### Q3: DOVETAIL CONSTRUCTION

Another important facet of Q12 is the required use of dovetail construction. A process that involves plywood side panels to perfectly interlock with a solid wood face frame through corresponding dovetail grooves. This highly resilient technique that Fabuwood introduced to the market guarantees that Q12 cabinet lines are secure, strong, and long-lasting.

### Q4: ANTI-WARP STRUCTURES

The anti-warp component involves the use of plywood panels comprised of rigid reinforcement beams. By applying the beams with a dovetail construction technique to secure all components, Fabuwood meets this standard ensuring a strong, reliable build that is resistant to distortion.

### Q5: WOODEN CORNER BLOCKS

For a cabinet to receive complete Q12 entitlement, wood must be used to help maintain structural integrity. To ensure a unified and organic design build, Fabuwood manufactures robust cabinet lines with wooden corner blocks, which keep the purity of an all-wood cohesive construction.

### Q6: SOLID BACK BUILDS

For superior structural longevity, this Q12 feature requires that the back of a cabinet is constructed from one piece of solid half-inch plywood. Fabuwood fulfills this standard by manufacturing cabinet backs with a strong and single piece of plywood to ensure durable strength and dimensional stability.

### Q7: FLUSH FIT FRAMES

In order to be considered Q12 compliant, a cabinet must have flush inner frames that provide an attractive appearance while giving added dimension to the internal area. Fabuwood's Q12 lines display prime craftsmanship with their flat surface top and bottom interior planes that result in convenient and practical usage.

### Q8: FINISHED INTERIORS

Treated and finished cabinet interiors are another significant feature of Q12 as they produce a clear statement of quality and attention to detail. As opposed to manufacturing with an applied lining, Fabuwood's vigorous top treatment techniques create a refined and durable design that is free of bubbling, peeling and chipping.

### Q9: SOFT-CLOSING ACTION

Another great characteristic of the Q12 qualification is the use of compact hinges with built-in, soft-close mechanism. Fabuwood uses the smooth-running capability and soft closing action of Blum's tandem plus blumotion hinges, providing an impeccably gentle and fluid cabinet function.

### Q10: FLUID FULL-EXTENSION

Cabinets built with smooth full-extension glides guarantee an enhanced running action that maximizes a cabinet's storage to its full capacity and ensures Q12 eligibility. Fabuwood manufactures Q12 cabinets with Blum's tandem plus runners and soft-closing technology, precisely utilizing space while also preventing damage and depreciation.

### Q11: EZ LEVEL DRAWER FRONTS

To ensure proper door alignment and function, a Q12 cabinet requires an effortless system utilizing a degree of mechanical precision for installing perfectly positioned drawer faces. Fabuwood innovates with a unique technique using circular discs that allow for easy 3/8" adjustments in any direction, resulting in a Q12 cabinet that achieves an aesthetically graceful balance.

### Q12: SEALED SIGNATURE

The final Q12 metric requires a thorough review at each manufacturing stage to ensure the completed product meets the provisions specified in the quality assurance system. Upon factory exit, a stamp of approval is given to show Fabuwood's commitment to quality control from the very first level of Q1 to the final Q12 stage, thus guaranteeing a superior and immaculate end product.